

07 Fixação do Tampo e da Moldura Superior e Lateral

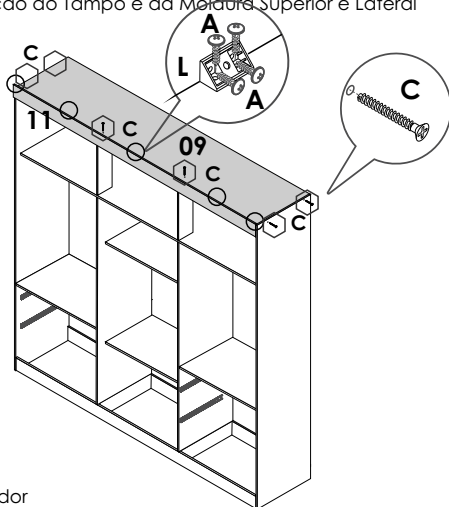

Sr. Montador
Favor fixar o conector de montagem
a 5mm da Borda fileada da Moldura Superior

08 Fixação das Costas

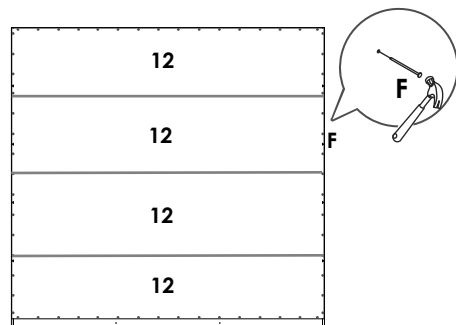

09 Montagem das Gavetas

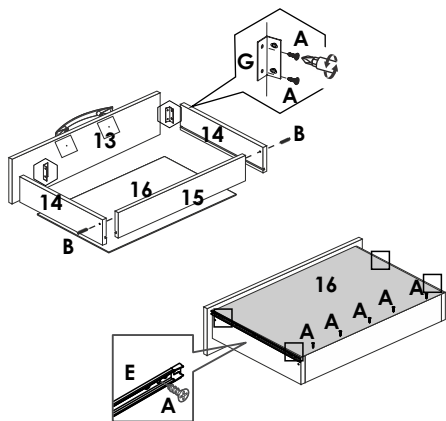

10 Montagem das Portas

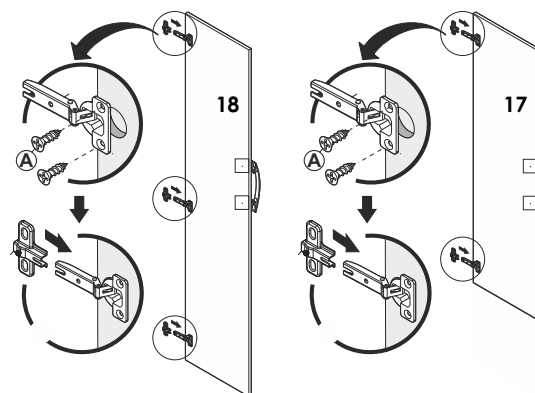

11 Fixação do Suporte Cabideiro

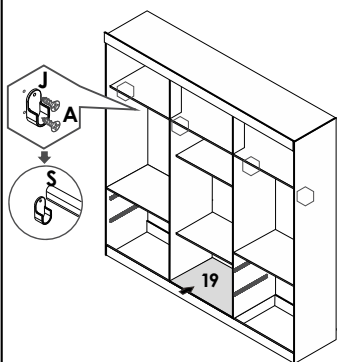

12 Colocação das Gavetas

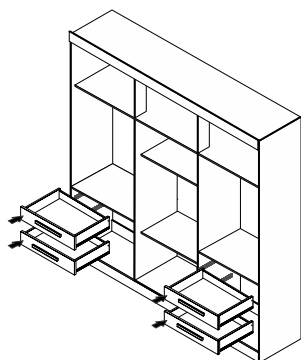

13 Fixação das portas

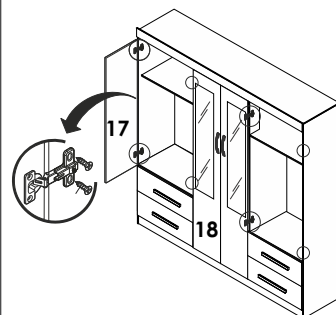

Sallêto *****
móveis



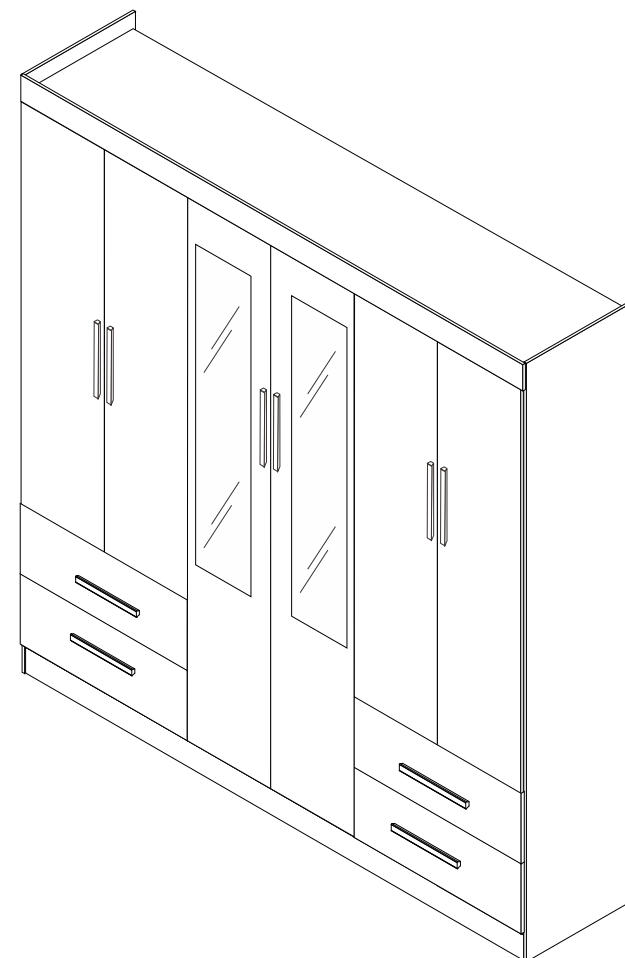











**ROUPEIRO 6 PORTAS
NEW VERONA**



LISTA DE PEÇAS

CÓD.	Nº.	DESCRIÇÃO	COMP.	LARG.	ESP.	QT
14328	01	Rodapé Frontal Pintado	1747	110	12	1
14329	02	Rodapé Traseiro Cru	1747	110	12	1
14313	03	Travessa Rodapé Cru	405	110	12	2
14309	04	Lateral Direita	2040	450	12	1
14310	05	Lateral Esquerda	20840	450	12	1
14326	06	Prateleira Menor Gaveta	574	450	12	2
14311	07	Prateleira Maior Recuado	574	330	12	2
14312	08	Divisão Direita Maior	1348	450	12	2
14327	09	Prateleira / Tampo	1746	450	12	2
14314	10	Batente Superior Porta	450	110	12	1
14335	11	Moldura Superior	1770	110	15	1
14330	12	Costas do Roupeiro	1765	453	3	4
14317	13	Frente da Gaveta	582	228	15	4
14318	14	Lateral da Gaveta	390	110	15	8
14319	15	Traseiro da Gaveta	520	70	15	4
14320	16	Fundo da Gaveta	537	400	3	4
14315	17	Portas Lateral Menor	1350	292	15	4
14316	18	Porta Central Maior	1815	290	15	2
14325	19	Base do Roupeiro sem furo	574	450	12	1

LISTA DE FERRAGENS

A  Parafuso 3,5x12 X186	B  Parafuso 3,5x40 (Traseiro Gaveta) X08	C  Parafuso 5x40 (montagem estrutural) X32
D  Parafuso 3,5x25 X20	E  Corrediça Metálica 350 mm X04	F  Prego 8x8 X80
G  Cantoneira 4 furos para gaveta X08	H  Cavilha 6x30 X26	I  Cavilha 6x50 X04
J  Suporte Cabide X04	K  Sapata X08	L  Conector X05
M  Puxador Gaveta X04	N  Puxador Porta X06	

Medidas em mm

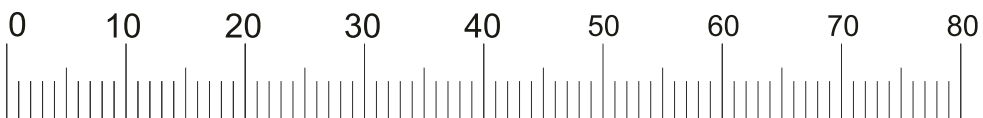

01 Início da Montagem

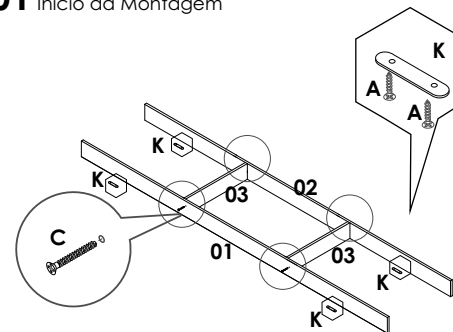

02 Montagem das Laterais

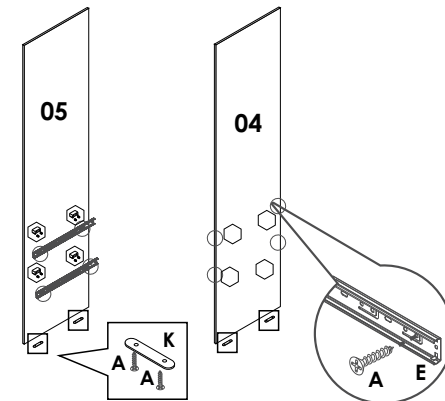

03 Montagem da Lateral Direita e Esquerda

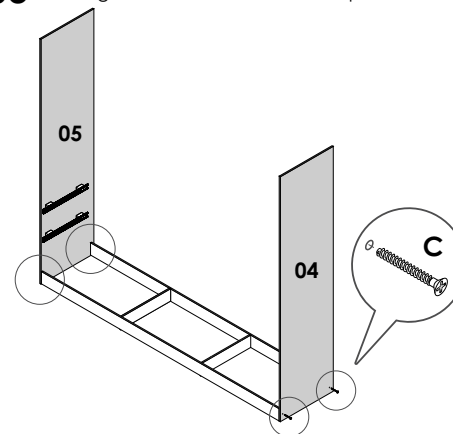

04 Fixação das Divisões

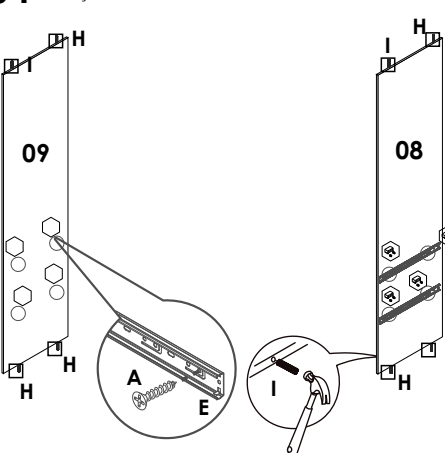

05 Montagem das Divisões na Base

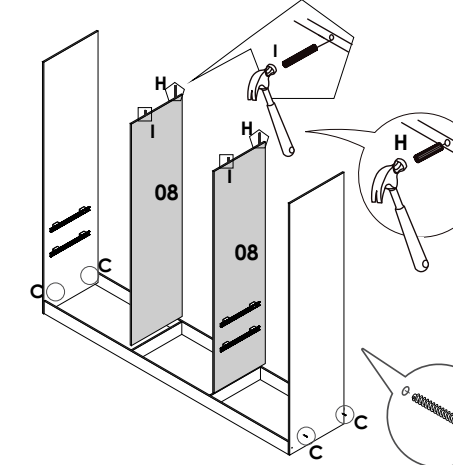

06 Montagem das Prateleiras e do Tampo Superior

