



**MAVAULAR** móveis

**Fone (32) 3539-7600**

Rod. Ubá - Rodeiro, Km 03 - Galpão 1

C. P. 050 - CEP 36500-000 - Ubá - MG

E-mail: [mavaular@mavaular.com.br](mailto:mavaular@mavaular.com.br) - Site: [www.mavaular.com.br](http://www.mavaular.com.br)

**Mavaular Móveis**



## Instruções de Montagem Aparador Arcus

Assembly Instructions Arcus

Instrucciones de montaje Arcus

CÓDIGO: 13244

Atualizado em:  
05/03/2024

### CUIDE BEM DO SEU MÓVEL

Dicas de limpeza e conservação:

- Para limpar corretamente seu produto, use sempre um pano liso e **levemente** umedecido com água;
- Não se esqueça de enxugar o seu móvel! Ele não deve permanecer úmido, pois a água pode prejudicar o acabamento ou causar mofo na madeira;
- Não se recomenda o uso de produtos à base de amoníaco.
- Não utilize esponja de aço ou qualquer material que possa arranhar a superfície do produto durante a limpeza.
- Não utilize plásticos ou papéis coloridos para forrar seu móvel.
- Evite arrastar objetos em cima do móvel. Eles podem riscar e prejudicar o acabamento de seu móvel de
- O material dos seus móveis tem um tratamento contra fungos e cupins, mesmo assim, em ambientes infestados recomenda-se a dedetização antes de instalar a seu móvel;
- Tente evitar a exposição direta ao sol. Sugere-se utilização de cortinas para proteger seu móvel;

### TAKING GOOD CARE OF YOUR FURNITURE

Cleaning and caring instructions:

- Wipe the wood furniture down with a moist cloth to properly clean the furniture.
- Do not forget to dry your furniture out. Humidity can damage the finish or create mould.
- Chemical products are not recommended;
- Never clean the furniture with scouring powders, steel scrubber pads or any other product which can scratch its surface.
- Furniture surfaces should not be covered with colored plastic or paper sheets.
- Avoid dragging objects on top of the furniture. They might scratch the finishing.
- Wood furniture are made of mould and termites resistant materials, however, it is recommended to use termiticides in infested places before installing the furniture.
- Avoid furniture exposure to direct Sun light. Drapers suggested.

### CUIDE BIEN DE SU MUEBLE

Indicaciones de limpieza y conservación

- Para limpiar correctamente su muebles de madera, siempre use un paño húmedo.
- No se olvide de secar su muebles! No debe permanecer húmedo, pues el agua puede perjudicar el acabado o causar moho en la madera.
- No es recomendable utilizar productos con amoníaco.
- No utilizar esponjas de acero o cualquier material que dañe la superficie de los muebles.
- No utilizar plásticos o papeles coloridos para forrar los muebles.
- Evite arrastrar objetos encima de los muebles. Ellos pueden riscar o dañar el acabado de su mueble de cocina.
- El material de los muebles tiene un tratamiento contra los hongos y las polillas, aun así, en ambientes infestados, se recomienda desinfectar antes de instalar su mueble.
- Evite la exposición directa al sol. Se sugiere la utilización de cortinas para proteger sus muebles.

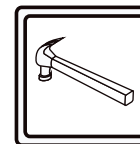
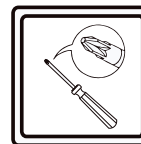
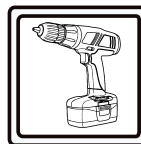
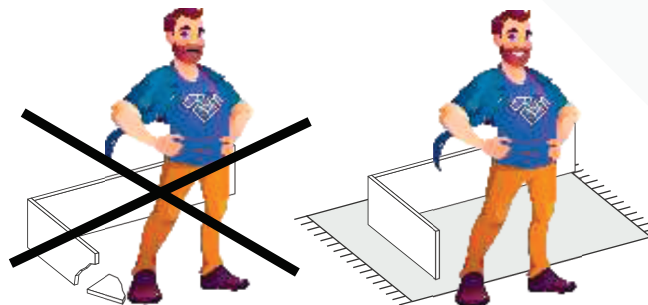
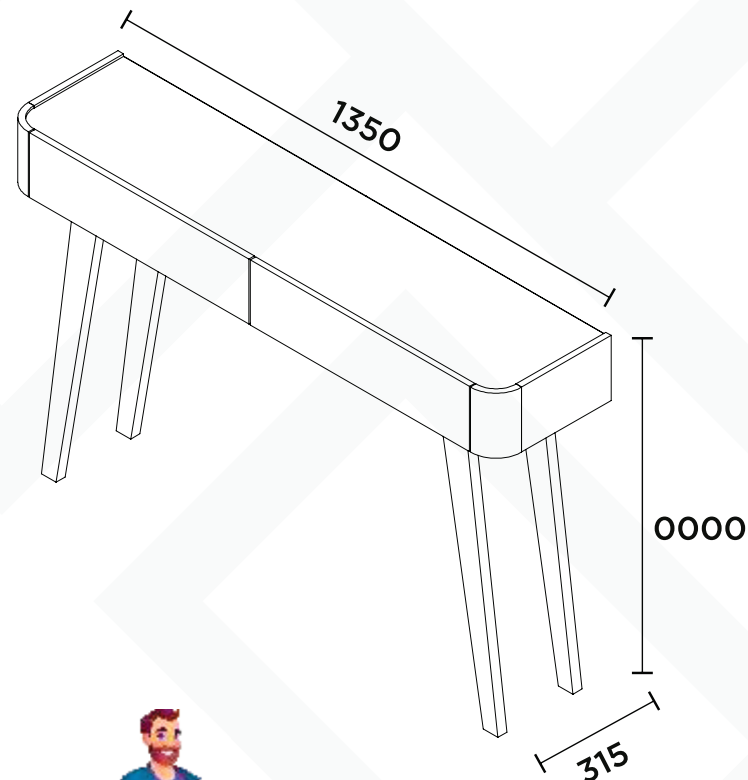

As ferramentas necessárias para montagem do produto não são fornecidas.  
The necessary tools for assembly aren't supplied.  
Las herramientas necesarias para armar los productos no son fornecidas.

N°	CÓDIGO CODE CÓDIGO	DESCRIÇÃO DESCRIPTION DESCRIPCIÓN			DIMENSÃO (mm)			QUANTIDADE QUANTITY CANTIDAD
					DIMENSION (mm)			
					COMP. LEN. LON.	LARG. WID. ANC.	ESP. DEP. ESP.	
1	12988	Lateral direita	Right Side	Lado derecha	255	154	15	1
2	13379	Lateral esquerda	Left Side	Lado izquierda	255	154	15	1
3	12983	Tampo	Cover	Cubrir	1305	300	15	1
4	12986	Divisão central do nicho	Central division of the niche	División central del nicho	299	114	15	1
5	12987	Distanciador direito	Right spacer	Espaciador derecho	299	70	15	1
6	13378	Distanciador esquerdo	Left spacer	Espaciador izquierdo	299	70	15	1
7	12984	Base	Base	Base	1305	300	15	1
8	13253	Moldura curva	Curved frame	Marco curvo	154	70	15	2
9	12985	Frente de gaveta	Drawer front	Frente del cajón	603	154	15	2
10	12989	Lateral de gaveta direita	Right drawer side	Lado derecho del cajón	250	96	15	2
11	13380	Lateral de gaveta esquerda	Left drawer side	Lado izquierdo del cajón	250	96	15	2
12	12991	Fundo de gaveta	Drawer bottom	Fondo del cajón	548	248	3	2
13	12990	Traseiro de gaveta	Drawer back	Fondo del cajón	534	90	15	2
14	13620	Costas	Back	Respaldo	665	138	3	2
15	13710	Pé esquerdo	Left foot	Pié izquierdo	670	55	30	2
16	13622	Pé direito	Right foot	Pié derecho	670	55	30	2
17	13711	Travessa do pé	Batten foot	Traviessa do pié	857	50	30	2
18	13712	Travessa menor	Small batten	Traviessa menor	237	50	30	2

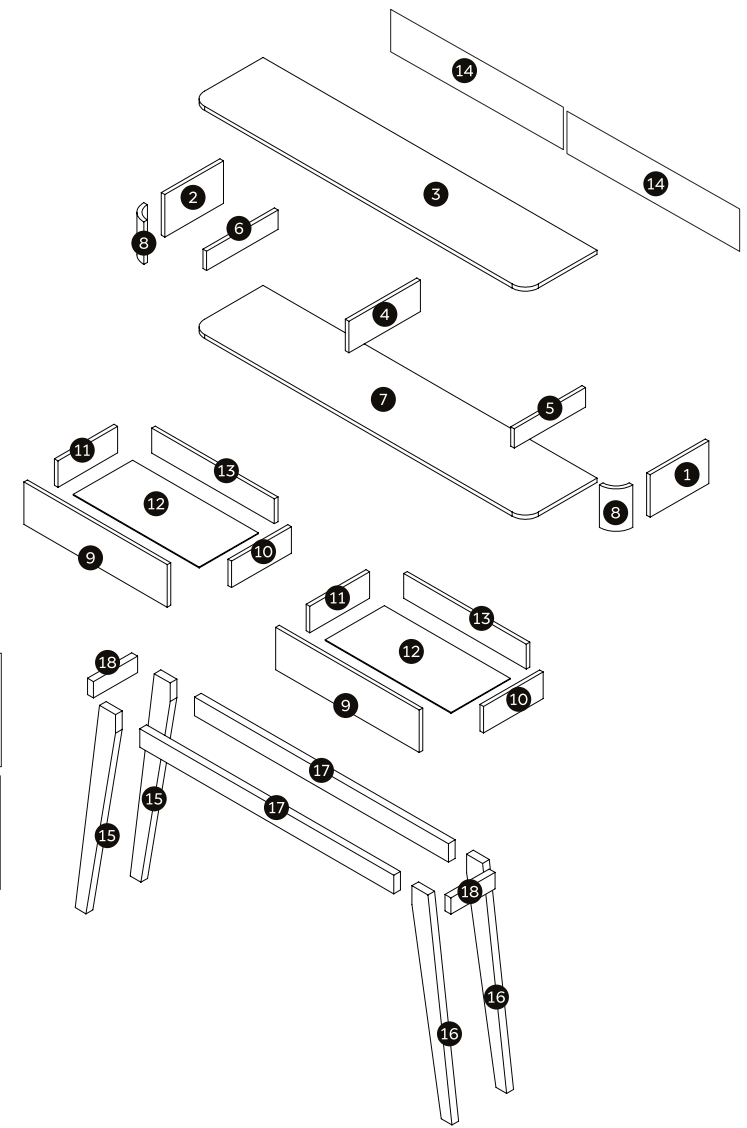

**A5 - CAVILHA MADEIRA 6X50** **04**  
6X50 WOODEN DOWEL  
TARUGO DE MADEIRA 6X50

**B2 - PARAFUSO 4,0X40MM** **06**  
4,0X40MM SCREW  
TORNILLO 4,0X40MM

**B3 - PARAFUSO 3,5X14MM** **24**  
3,5X14MM SCREW  
TORNILLO 3,5X14MM

**B5 - PARAFUSO 7X60MM** **04**  
7X60MM SCREW  
TORNILLO 7X60MM

**B6 - PARAFUSO MINIFIX** **18**  
SCREW MINIFIX  
TORNILLO MINIFIX

**B12 - PARAFUSO 3,0X14MM** **04**  
3,0X14MM SCREW  
TORNILLO 3,0X14MM

**B13 - PARAFUSO 3,0X12MM** **04**  
3,0X12MM SCREW  
TORNILLO 3,0X12MM

**B16 - PARAFUSO 3,5X30MM** **08**  
3,5X30MM SCREW  
TORNILLO 3,5X30MM

**B17 - PARAFUSO 3,5X14MM** **20**  
3,5X14MM SCREW  
TORNILLO 3,5X14MM

**B23 - PARAFUSO 7X110MM** **08**  
7X110MM SCREW  
TORNILLO 7X110MM

**C1 - CONECTOR PLÁSTICO** **06**  
PLASTIC CONNECTOR  
CONECTOR PLASTICO

**C3 - BUCHA PARA MINIFIX** **18**  
BUSHING FOR MINIFIX  
CASQUILLO PARA MINIFIX

**C4 - SUPORTE FUNDO DE GAVETA** **04**  
BACKGROUND SUPPORT  
SOPORTE

**E2 - TAPA FURO 13MM** **04**  
HOLE COVER 13MM  
TAPA AGUJERO 13MM

**E4 - TAMPA MINIFIX** **18**  
COVER  
TAPA

**E6 - BATENTE DE SILICONE** **04**  
SILICON STOP  
TOPE DE SILICIO

**F1 - PREGO 10X10** **14**  
NAIL  
CLAVO

**G1 - FIXADOR DE COSTAS** **02**  
BACK FIXER  
FIJADOR DE ESPALDA

**I1 - CHAVE ZETA 4MM** **01**  
4MM ALLEN WRENCH  
LLAVE CETA 4MM

**I2 - CHAVE ZETA 6MM** **01**  
6MM ALLEN WRENCH  
LLAVE CETA 6MM

**I3 - GIZ PARA RETOQUE** **01**  
TOUCH-UP CHALK  
TIZA DE RETOQUE

**I4 - CANTONEIRA 2 FUR0S** **02**  
CORNNER  
ESQUINA

**I7 - BUCHA DO PÉ** **04**  
BUSHING  
COJINETE

**I8 - SAPATA REGULÁVEL** **04**  
ADJUSTABLE SHOE  
ZAPATO AJUSTABLE

**I9 - TAMBOR MINIFIX** **18**  
MINIFIX DRUM  
TAMBOR MINIFIX

**J1 - PAR DE CORREDIÇA** **02**  
PAIR OF SLIDES  
PAR DE RIELES

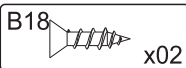
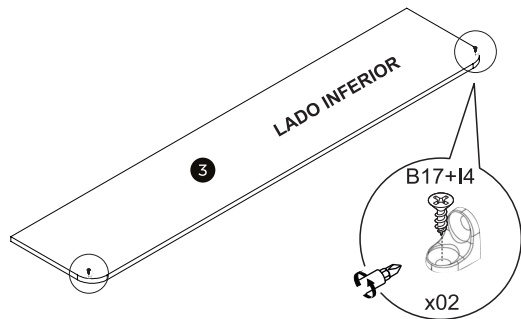
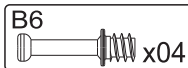
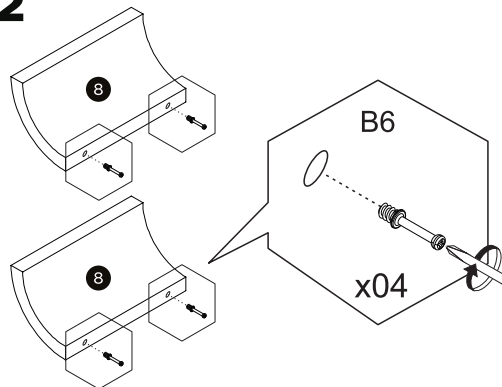
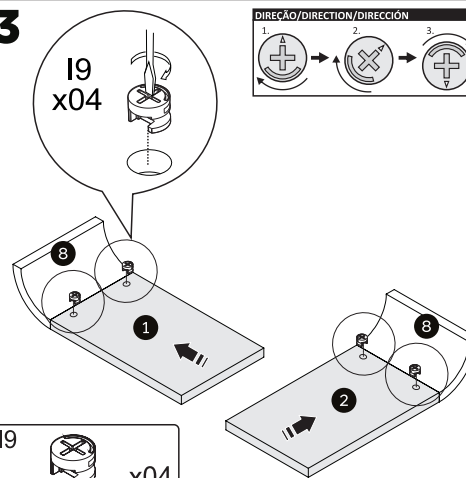
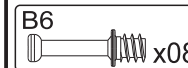
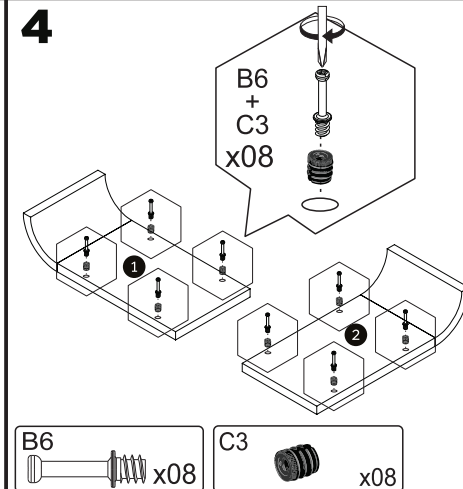
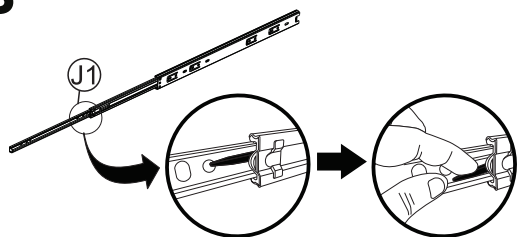
**1****2****3****4****5**

Abaixe a alça preta e retire a peça J1 conforme abaixo.  
Push the black pin down to remove the J1 part.  
Empujar para abajo la pieza negra para retirar la parte J1.

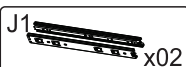
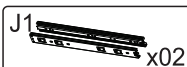
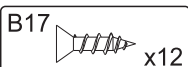
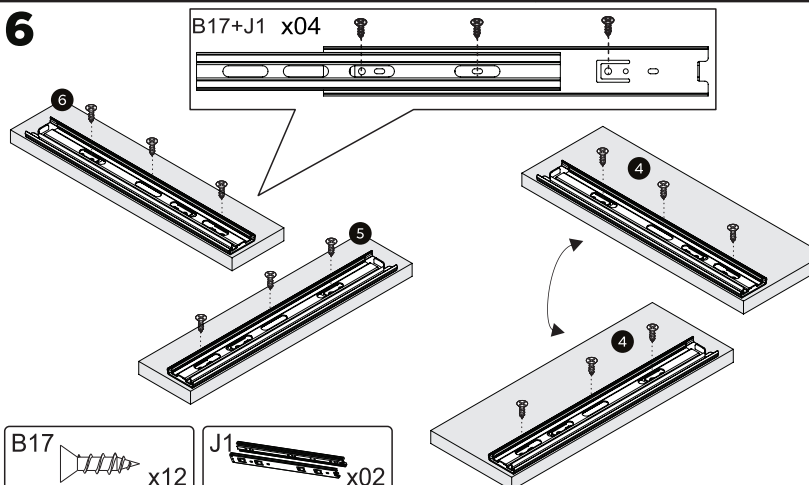
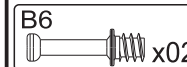
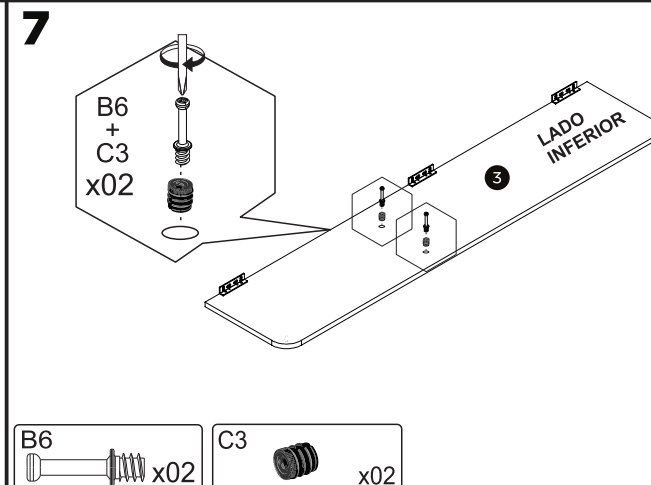
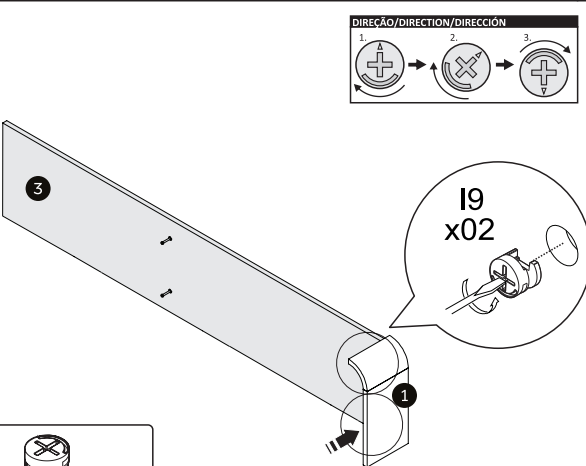
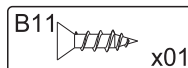
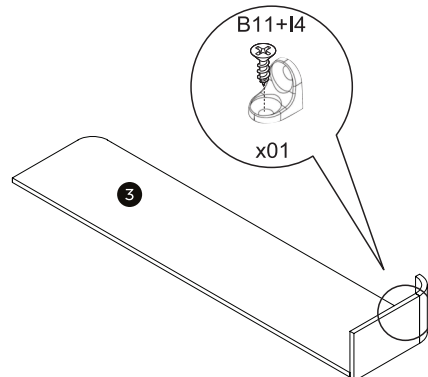
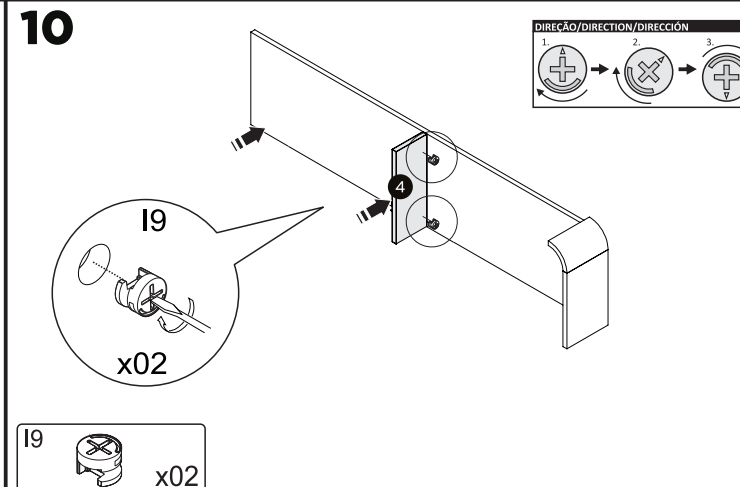
**6****7****8****9****10**

**11** FIXAR A PEÇA 7 PRIMEIRO.  
DEPOIS FIXAR A PEÇA 2.

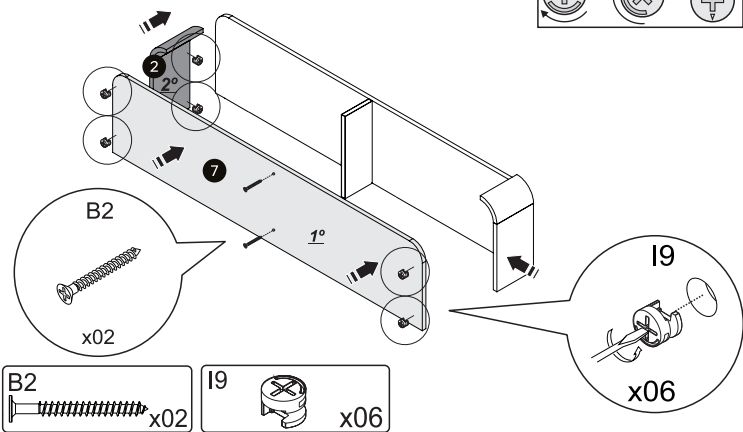

**12**

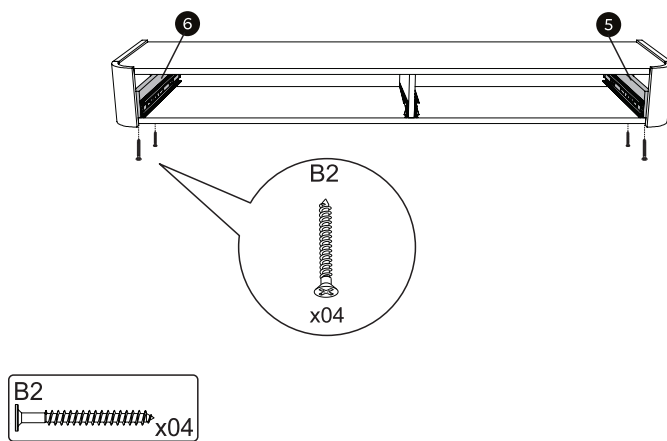

**13**

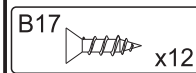
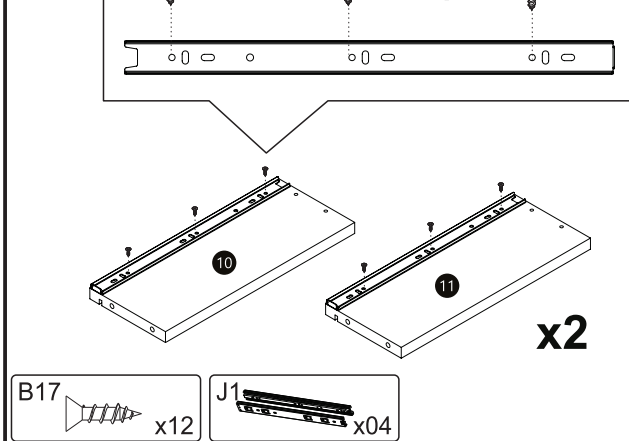

**14**

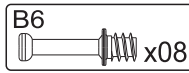
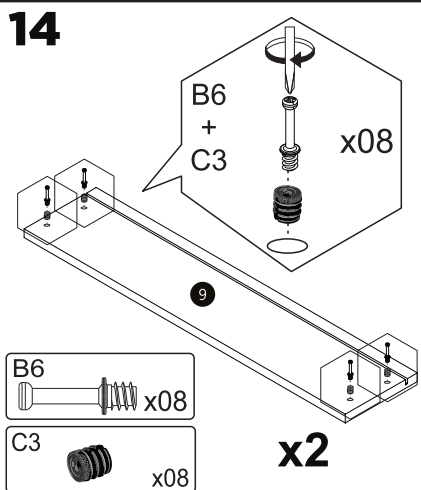

**15**

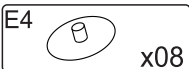
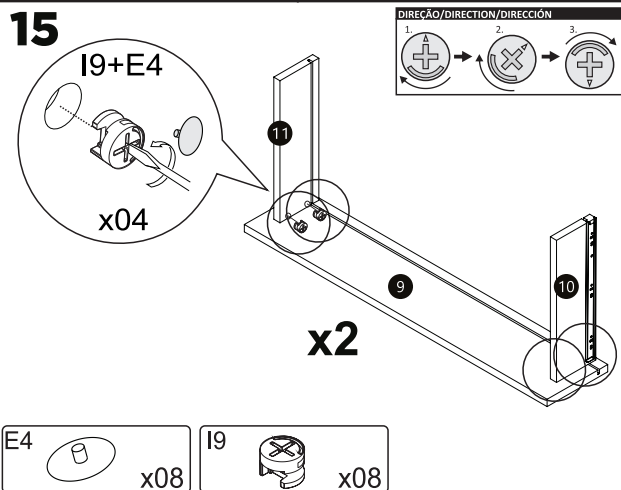

**16**

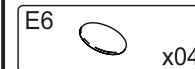
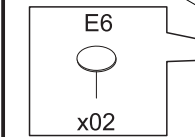
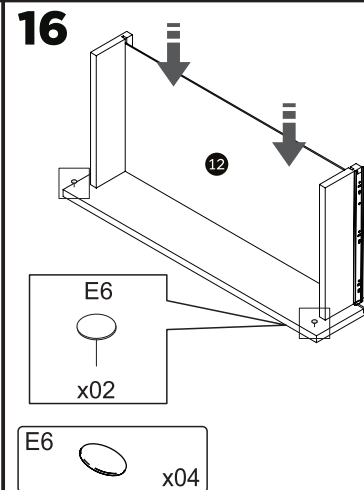

**17**

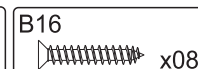
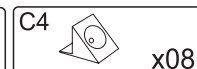
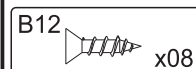
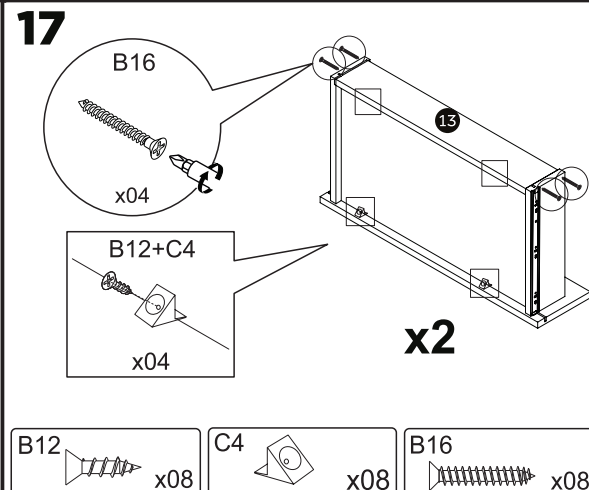

**18**

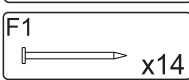
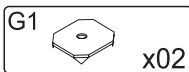
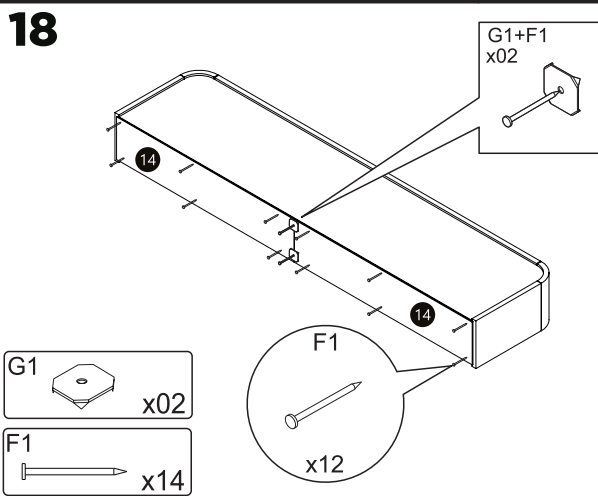

**19**

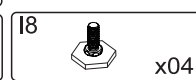
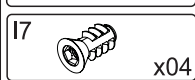
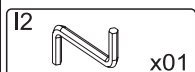
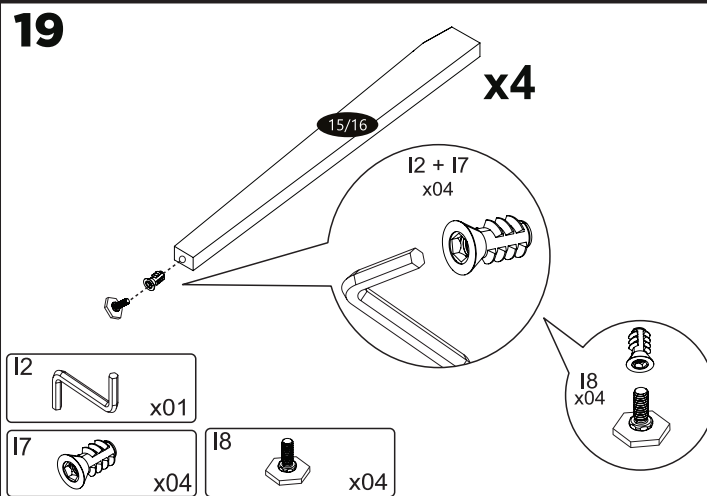

**20**

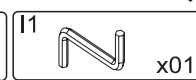
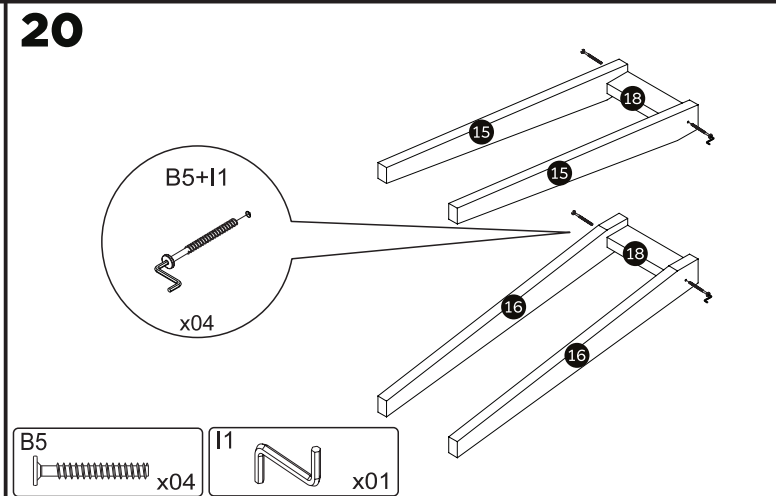

21

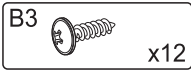
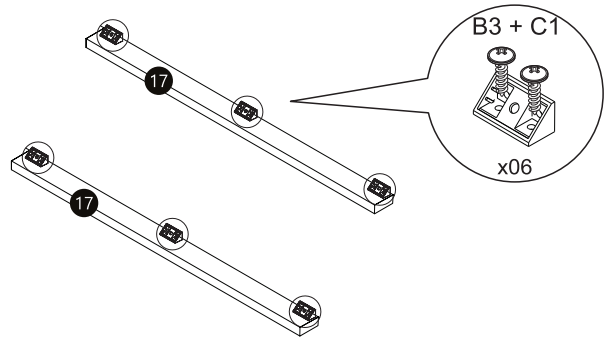

22

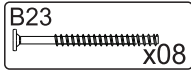
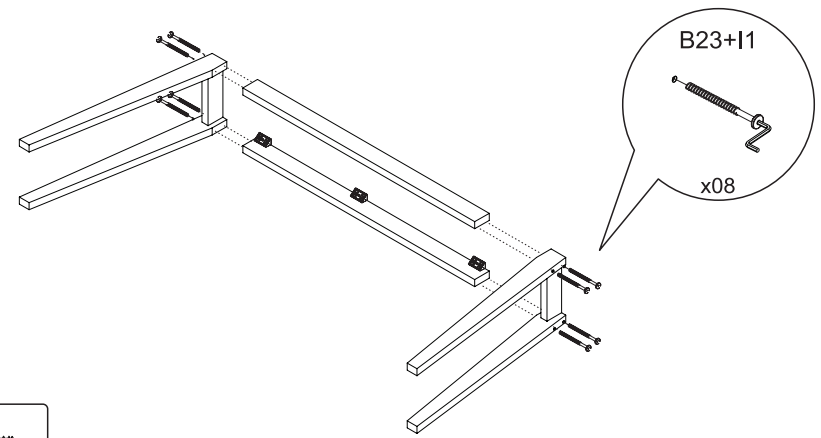

23

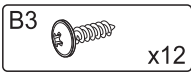
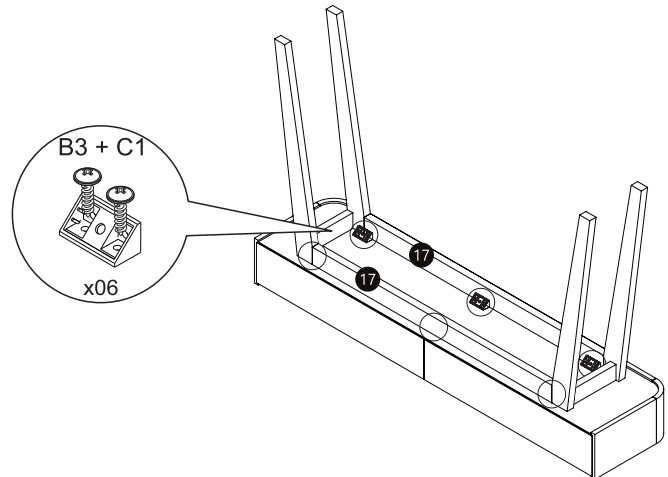

24

