

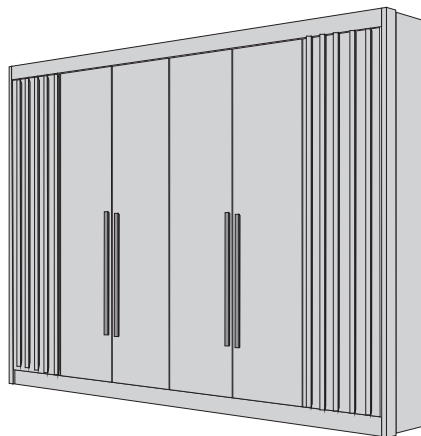

ROUPEIRO SAO CARLOS

código - 22156



ACESSE O VÍDEO
DESTE PRODUTO

INSCREVA-SE NO CANAL

Abra a câmera do seu
celular e
escaneie o qr code.



ESQUEMA DE MONTAGEM

12/04/2024

<p>Montagem Estrutura Roupeiro</p> <p>Parafuso 4,0 x 40 cabeça chata 56 UN</p>	<p>Parafuso 3,5 x 12 cab. chata 212 UN</p>	<p>Parafuso 3,5 x 30 cabeça chata 08 UN</p>
<p>Parafuso 3,5 x 35 cabeça chata 38 UN</p>	<p>Puxador das Portas</p> <p>Parafuso 3,5 x 25 flangeado 26 UN</p>	<p>Fixar Costa Prego 10 x 10</p> <p>120 UN</p>
<p>Cavilha 6 x 30 38 UN</p>	<p>Distanciador e Correções</p> <p>Parafuso 3,5 x 35 Flangeado 48 UN</p>	<p>Cantoneira Plástica 04 UN</p>
<p>Cantoneira Metálica 14 UN</p>	<p>Suporte Cabide 06 UN</p>	<p>Sapata Plástica 08 UN</p>
<p>GIZ 01 UN</p>	<p>Dobradiça 24 UN</p>	<p>Etiqueta Leifer 01 UN</p>
		<p>COLA Sachê de Cola 01 UN</p>

Nº	DESCRIÇÃO	QT.	CINAMOMO	FREIJO	BRANCO
01	RODAPÉ FRONTAL	01	22161	22161	22161
02	RODAPÉ TRASEIRO	01	22162	22162	22162
03	RODAPÉ CENTRAL	02	22164	22164	22164
04	BASE	01	22181	22181	22181
05	LATERAL ESQUERDA	01	22183	22183	22183
06	DIVISAO ESQUERDA	01	22184	22184	22184
07	DIVISAO CENTRAL	01	22193	22193	22193
08	DIVISAO DIREITA	01	22194	22194	22194
09	LATERAL DIREITA	01	22182	22182	22182
10	PRATELEIRA GAVETEIRO	02	22195	22195	22195
11	PRATELEIRA MENOR INFERIOR	03	22197	22197	22197
12	PRATELEIRA MENOR SUPERIOR	04	22196	22196	22196
13	PRATELEIRA MALEIRO	02	22198	22198	22198
14	TAMPO SUPERIOR	01	22199	22199	22199
15	MOLDURA SUPERIOR	01	22202	22202	22202
16	MOLDURA LATERAL	02	22200	22200	22200
17	CABIDEIRO	02	----	----	----
18	CALCEIRO	01	----	----	----
19	COSTAS	05	22204	22204	22204
20	PORTA CENTRAL	04	22214	22214	22214
21	PORTA RIPADA	02	22213	22213	22213
22	FRENTE DE GAVETA	04	22206	22206	22206
23	LATERAL DE GAVETA	08	19239	19239	19239
24	FUNDO DE GAVETA	04	22210	22210	22210
25	TRASEIRO DE GAVETA	04	22208	22208	22208
26	DISTANCIADOR FRONTAL	04	22211	22211	22211
27	DISTANCIADOR TRASEIRO	04	22212	22212	22212
28	KIT FERRAGEM	01	23255	23255	23255

Atenção Sr. Montador Montagem da Moldura Superior

Para montagem da moldura superior usar CANTONEIRA PLÁSTICA 04 FUROS E PARAFUSO 3,5X12. Após parafusar as 04 Cantoneiras na Moldura superior, levar a moldura até o tampo superior nº 14 e parafusar de baixo para cima usando parafuso 3,5x12.

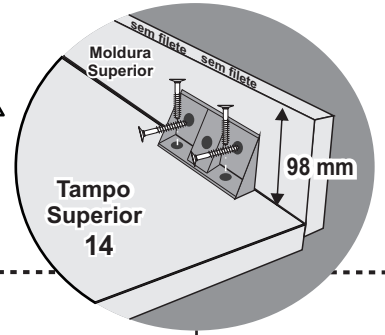

Parafusar as 04 Cantoneiras dividindo elas conforme desenho abaixo.

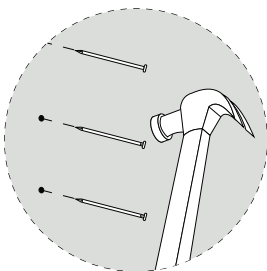
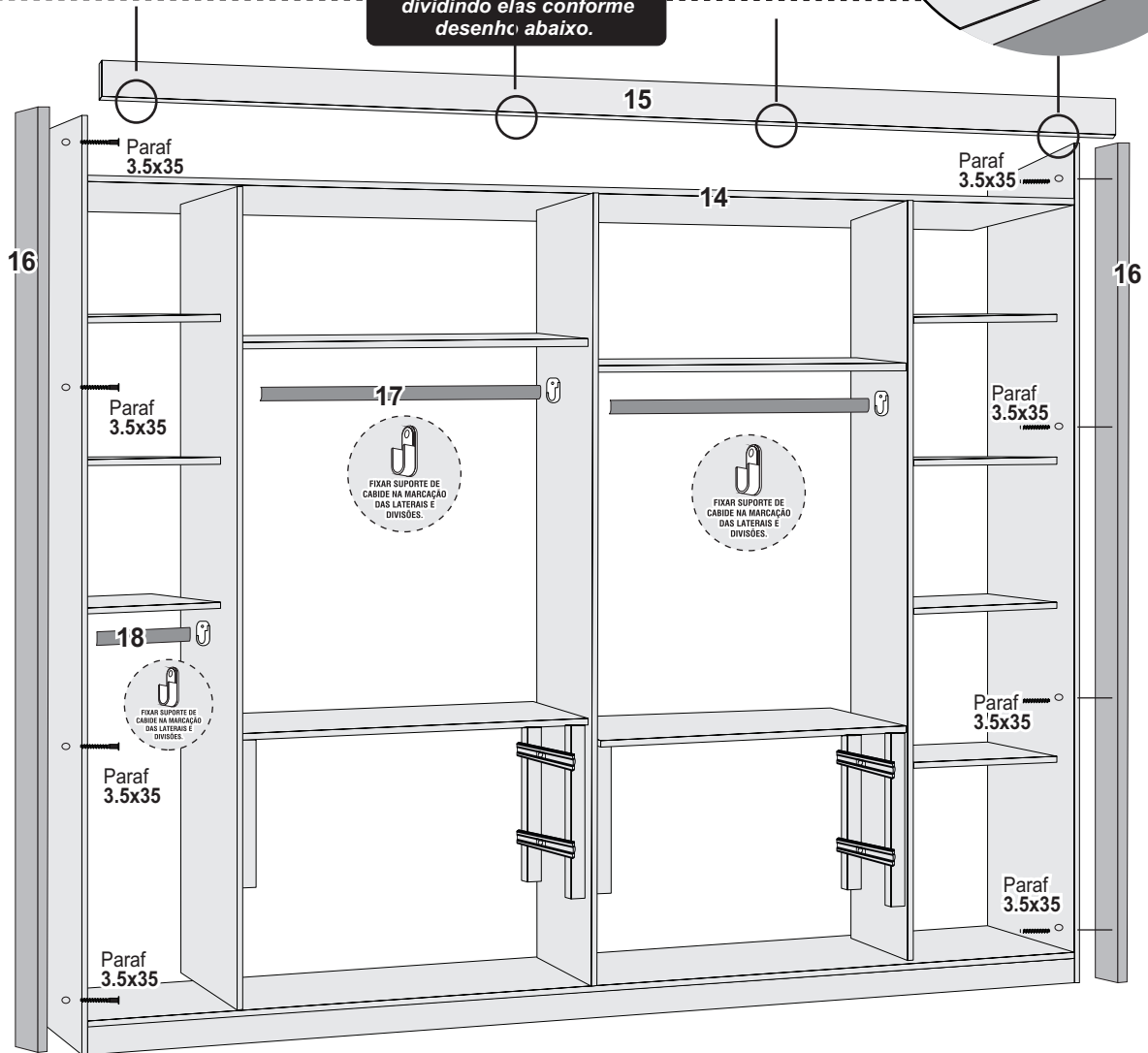

Fixar Costa
Prego 10 x 10

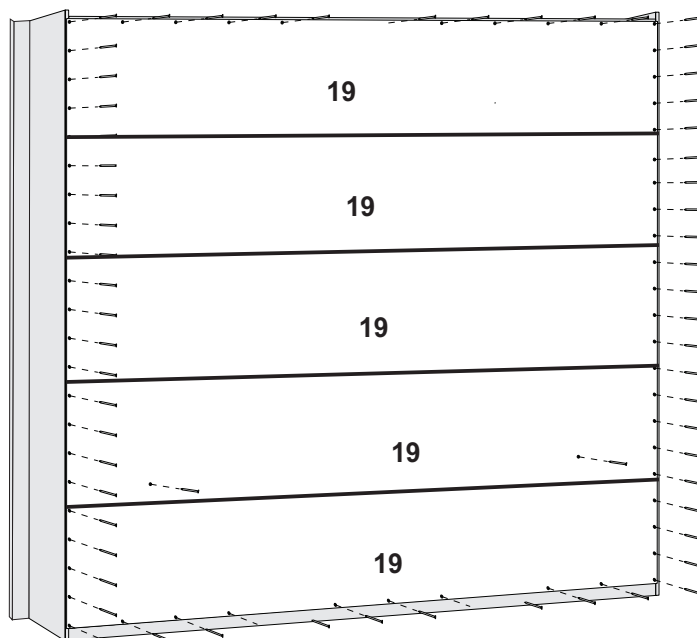

Montagem das Portas

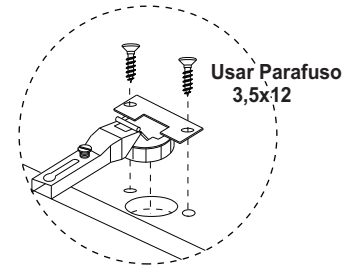
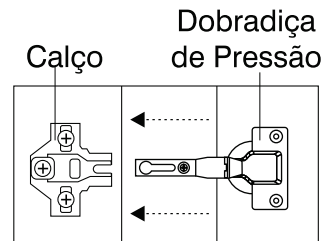
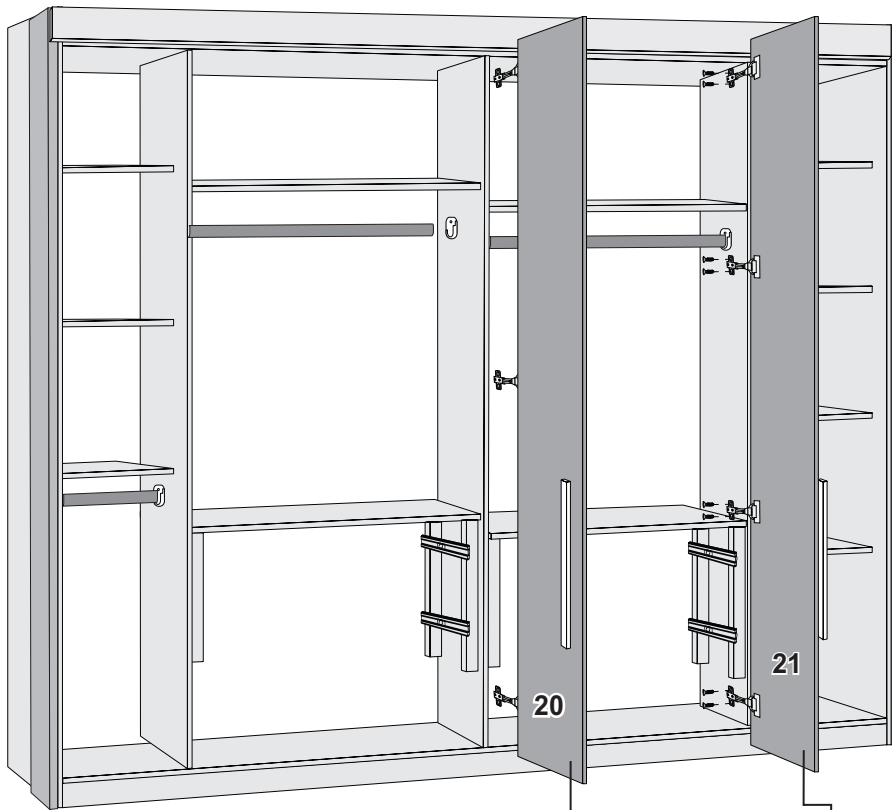

Usar este parafuso nos puxadores de madeira sendo 3 parafusos 3,5x25 em cada puxador.

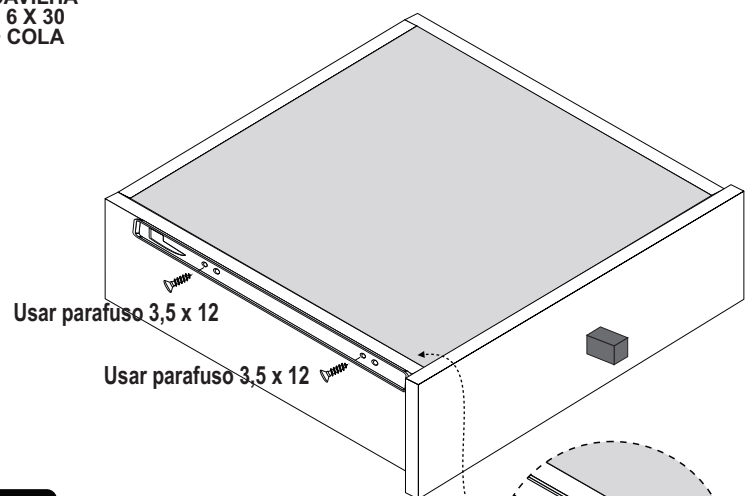
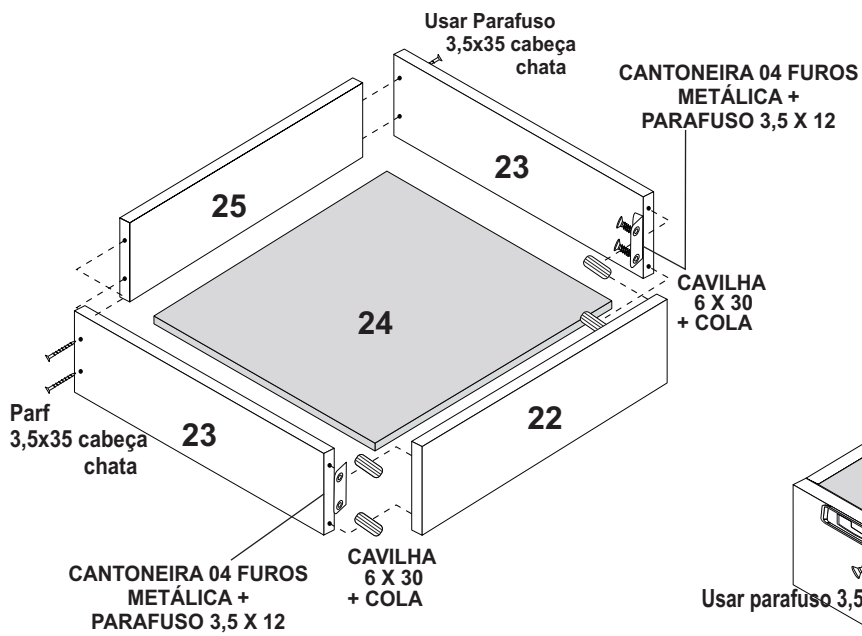

ATENÇÃO:
FAVOR FACEAR A CORREDIÇA NA BASE DA LATERAL, ENCOSTAR A MESMA NA FRENTE DA GAVETA EM SEGUIDA PARAFUSÁ-LA.

